Important Safety Instructions

When using your telephone equipment, basic safety precautions should always be followed to reduce the risk of fire, electrical shock, and injury to persons, including the following:

1. Read and understand all instructions.
2. Follow all warnings and instructions marked on the product.
3. Unplug this product from the wall outlet before cleaning. Do not use liquid cleaners or aerosol cleaners. Use a dry cloth for cleaning.
4. Do not use this product near water; for example, near a sink or in a wet area.
5. Do not place this product on an unstable cart, stand, or table. The telephone may fall, causing serious damage to the unit.
6. To protect the product from overheating, do not block or cover any slots or openings in the Base Unit. This product should never be placed near or over a radiator or heat register. This product should not be placed in a built-in installation unless proper ventilation is provided.
7. This product should be operated only from the type of power source indicated on the marking label.
8. Do not allow anything to rest on the power cord. Do not locate this product where the cord will be damaged by persons walking on it.
9. Do not overload wall outlets and extension cords, as this can result in the risk of fire or electrical shock.
10. Never push objects of any kind into this product through the Base Unit slots, as they may touch dangerous voltage points or short out parts that could result in a risk of fire or electric shock. Never spill liquid of any kind on the product.
11. To reduce the risk of electric shock, do not disassemble this product. Contact qualified service personnel when some service or repair work is required. Opening or removing covers may expose you to dangerous voltages or other risks. Incorrect reassembly can cause electric shock when the appliance is subsequently used.

12. Unplug this product from the wall outlet and refer servicing to qualified service personnel under the following conditions:
 - A. When the power supply cord is damaged or frayed.
 - B. If liquid has been spilled into the product.
 - C. If the product has been exposed to rain or water.
 - D. If the product does not operate normally when following the operating instructions. Adjust only those controls that are covered by the operating instructions. Improper adjustment of other controls may result in damage and will often require extensive work by a qualified technician to restore the product to normal operation.
 - E. If the product has been dropped or the cabinet has been damaged.
 - F. If the product exhibits a distinct change in performance.
13. Do not use the telephone to report a gas leak in the vicinity of the leak.

CAUTION

To reduce the risk of fire or injury to persons by the battery, read and follow these instructions:

1. Use only the appropriate type and size Battery Pack specified in this Operating Guide.
2. Do not dispose of the Battery Pack in a fire. The cell may explode. Check the Battery Disposal information at the beginning of this Guide for disposal instructions.
3. Do not open or mutilate the Battery Pack. Released electrolyte is corrosive and may cause damage to the eyes or skin. It may be toxic if swallowed.
4. Exercise care in handling the battery in order not to short out the battery with conducting materials such as rings, bracelets, and keys. The battery or conductor may overheat and cause burns.
5. Charge the Battery Pack provided with or identified for use with this product only in accordance with the instructions and limitations specified in the instruction manual provided for this product.
6. Observe proper polarity orientation between the Battery Pack and battery charger.

SAVE THESE INSTRUCTIONS

Introduction

About the EXP91

The EXP91 is a 900 MHz Cordless Phone. It is designed and engineered to exacting standards for reliability, long life, and outstanding performance.

Features

- 900 MHz operation
- Any Key Answer
- 10-Number Memory
- Voice Scramble
- Wall mountable
- Battery Saving Feature
- Handset Volume Control
- Redial and Flash
- Automatic Digital Code Security
- Extended range and clarity
- One-Way Page/Find
- AutoTalk
- AutoStandby
- 40 Channels
- Tone/Pulse Dialing
- Ringer Volume Control
- Hearing aid compatible

The EXP91 features include *AutoTalk™* and *AutoStandby™*. *AutoTalk™* allows you to answer a call by just removing the Handset from the Base so you don't have to waste time pushing buttons or flipping switches. *AutoStandby™* allows you to hang up by simply returning the Handset to the Base.

The *UltraClear Plus* true compander circuitry virtually eliminates background noise. This innovative technology, together with 40 different channels, provides you with the best possible reception during all your conversations.

To protect you against misbilled calls which might result from your phone being activated by other equipment, the EXP91 has *Random Code™* digital security which automatically selects one of over 65,000 digital security codes for the Handset and Base Unit. Also, the *AutoSecure™* feature electronically locks your phone when the Handset is in the Base. To get the most from your EXP91, **please read this Operating Guide thoroughly.**

What's Included with Your EXP91



EXP91 Base

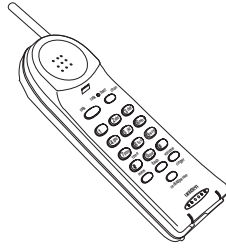

EXP91 Handset

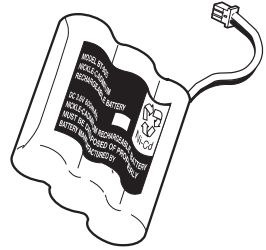

Rechargeable Battery

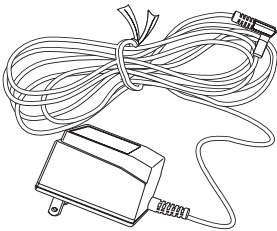

AC Adapter

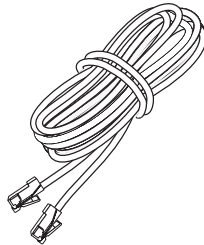

Long Telephone Cord

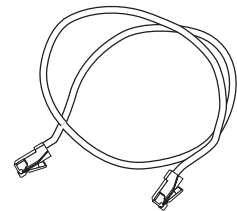

Short Telephone Cord

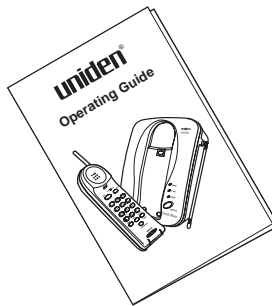

Operating Guide

If any of these items are missing or damaged, contact your place of purchase.

Installation

Installing Your EXP91

Selecting the Installation Location

Select a location for the EXP91 to avoid excessive heat or humidity (as in a kitchen or bathroom). The Base Unit of your EXP91 can be placed on a desk or tabletop near a standard 120V AC outlet and telephone line jack, mounted on a standard AT&T or GTE wall plate, or mounted directly on the wall. Keep the Base Unit and Handset away from sources of electrical noise (motors, fluorescent lighting, etc.). Be sure there is sufficient space to safely extend the Base Unit antenna fully.

Connecting the Telephone Line

There are three types of phone outlets:

- Modular.
- 4-prong jack.
- Hard-wired type.

Modular Jack

Plug the telephone line cord from the Base Unit into a standard modular telephone jack. If you do not have a modular jack, contact your local telephone company for information on the installation of these jacks.

4-Prong Jack

An adapter (not included) is required. The adapter plugs into the 4-prong jack and the telephone line cord plugs into the adapter.

Hard-wired Jack

A modular jack converter (not included) is required. You may need to rewire when connecting the converter (making color-coded connections).

✿ *Your Uniden Cordless Telephone Dealer or a telephone supply store can advise you on the proper adapter or converter.*

CAUTION:

- Never install telephone wiring during a lightning storm.
- Never install telephone jacks in wet locations unless the jack is specifically designed for wet locations.
- Never touch uninsulated telephone wires or terminals unless the telephone line has been disconnected at the network interface.
- Use caution when installing or modifying telephone lines.

Setting the Dial Mode Switch

Place the switch in the **T** position for tone dialing, or the **P** position for pulse dialing.

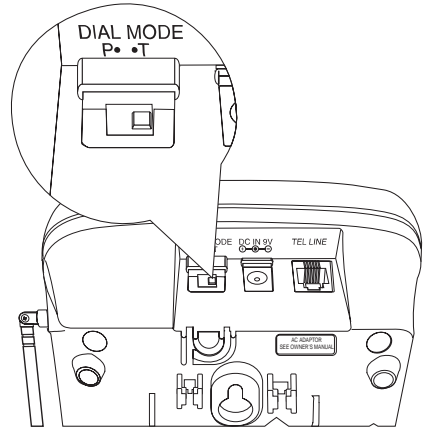

Desk or Tabletop Installation

1. Plug the AC adapter cord into the 9V DC input jack on the Base Unit.

Note: Place the AC adapter cord inside the molded strain-relief.

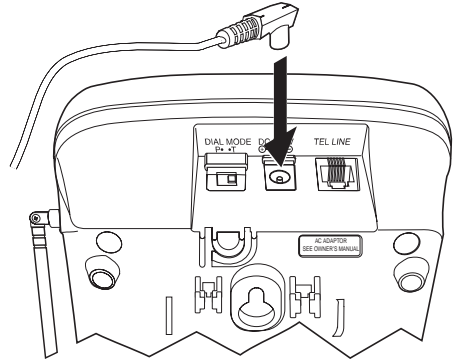

2. Plug one end of the long telephone cord into the **TEL LINE** jack on the Base Unit.

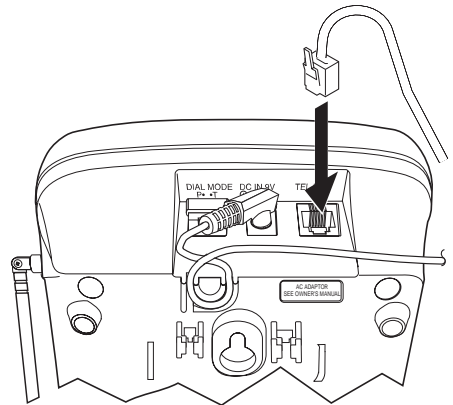

3. Raise the antenna on the Base Unit.

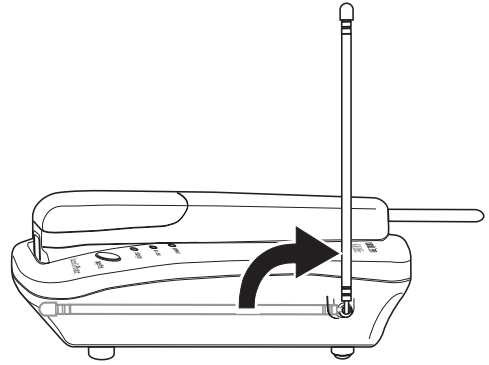

4. Plug the other end of the telephone cord into the telephone wall jack.

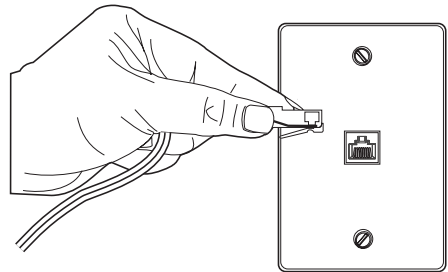

5. Plug the AC Adapter into a standard 120V AC wall outlet.

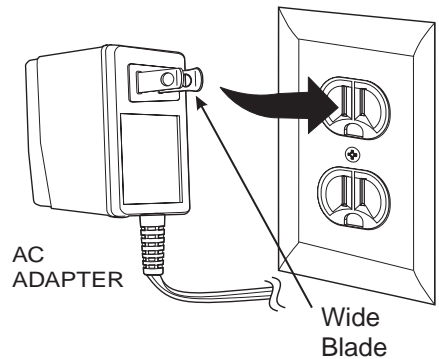

Note: Use only the AC Adapter supplied with the EXP91.



* Place the telephone and power cords where they will not create a trip hazard, or where they could become chafed and create a fire or other electrical hazards.

Wall Installation

Setting the Handset Retainer

1. Remove the Handset Retainer on the Base Unit by sliding it upward.

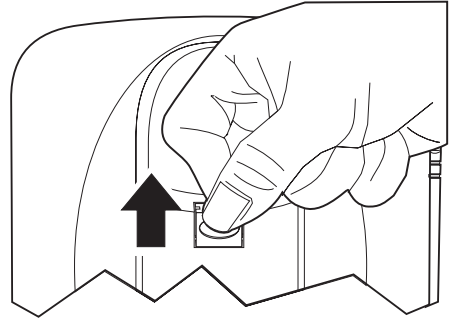

2. Flip the Retainer over so the tab is facing up.

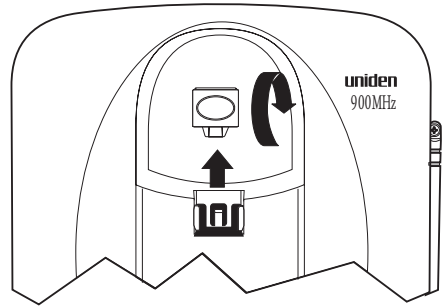

3. Slide the Retainer back into the Base Unit.

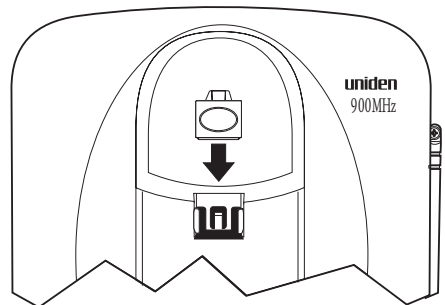

Mounting on a Standard Wall Plate

The EXP91 is designed to be mounted on a standard AT&T or GTE wall plate.

1. Plug the AC Adapter into the Base Unit.

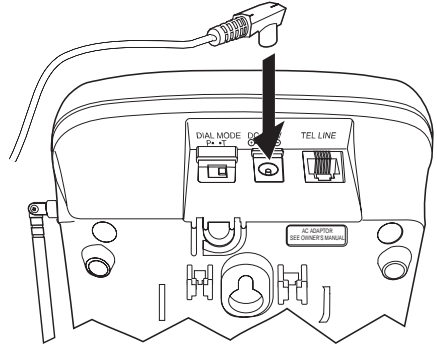

2. Place the AC Adapter cord inside the left channel cord holder.

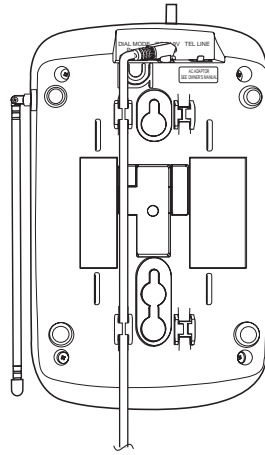

3. Plug the short telephone cord into the phone and the wall plate jack.

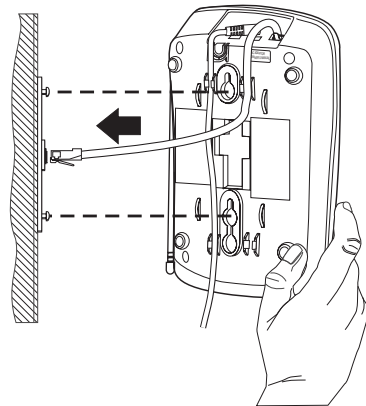

4. Place the Base Unit on the two posts of the wall plate and slide downward to secure.

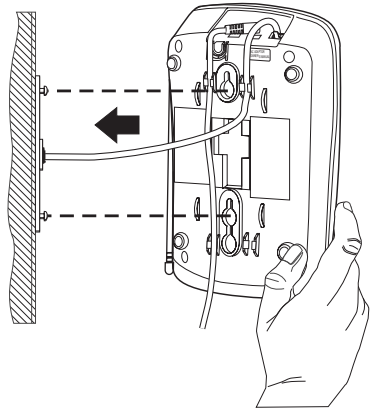

5. Raise the antenna on the Base Unit.

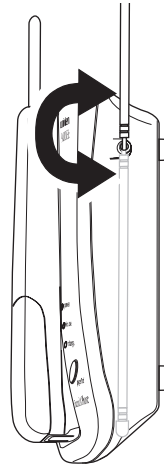

6. Plug the AC Adapter into a standard 120V AC wall outlet.

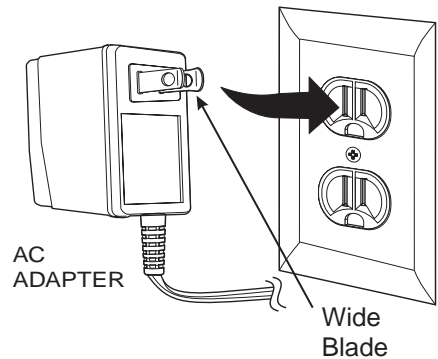

Note: Use only the AC Adapter supplied with the EXP91.



* Route the power cord where it will not create a trip hazard, or where it could become chafed and create a fire or other electrical hazards.

Mounting Directly on a Wall

If you do not have a standard wall plate, you can mount the EXP91 directly on a wall. Before mounting your cordless telephone, consider the following:

- Select a location away from electrical cables, pipes, or other items behind the mounting location that could cause a hazard when inserting screws into the wall.
 - Make sure the wall material is capable of supporting the weight of the Base Unit and Handset; otherwise, damage to the unit could result.
 - Use #10 screws with anchoring devices suitable for the wall material where the Base Unit will be placed.
1. Insert the screws, with their appropriate anchor device, about $3 \frac{5}{16}$ inches apart. Allow about $\frac{3}{16}$ of an inch between the wall and screw heads for mounting the phone.

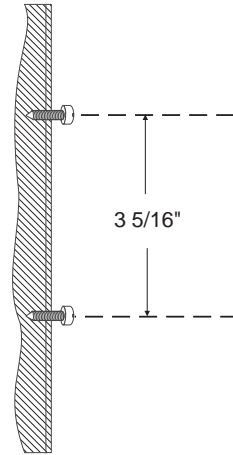

2. Plug the AC Adapter into the Base Unit.

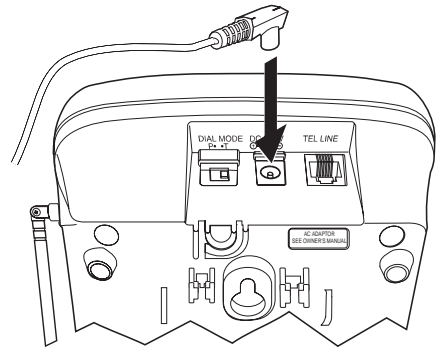

3. Place the AC Adapter cord inside the left channel cord holder.

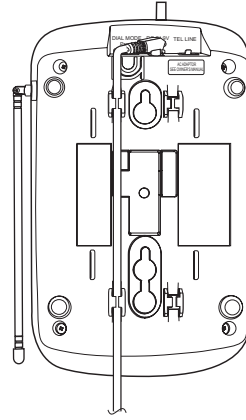

4. Plug one end of the long telephone cord into the **TEL LINE** jack on the Base Unit.

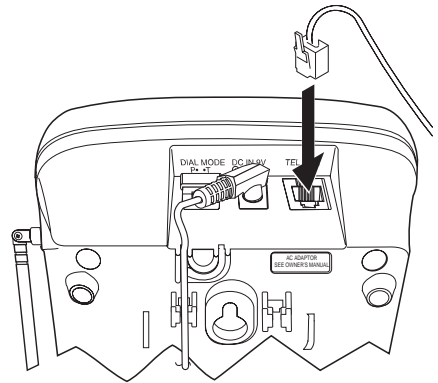

5. Place the telephone cord into the right channel cord holder.

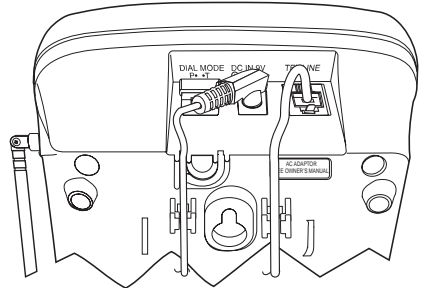

6. Place the Base Unit on the screws and push down until it's firmly seated.

After the unit is mounted, raise the antenna.

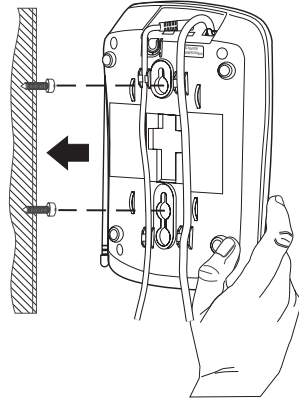

7. Plug the other end of the telephone line into the telephone wall jack.

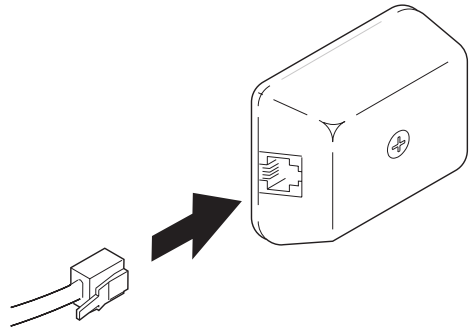

8. Plug the AC Adapter into a standard 120V AC wall outlet.

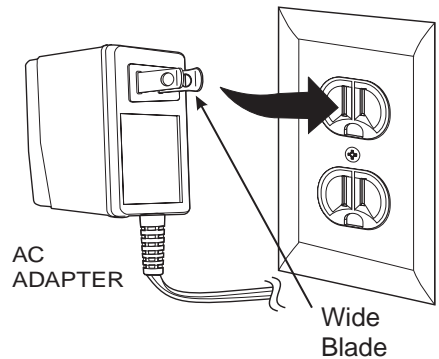

Note: Use only the AC Adapter supplied with the EXP91.



* Route the telephone and power cords where they will not create a trip hazard, or where they could become chafed and create a fire or other electrical hazards.

Installing the Battery Pack

Note: *The built-in Memory Backup feature allows up to 3 minutes after disconnecting the old Battery Pack to install a new one without losing any phone numbers that may be stored in the telephone's memory.*

To install or replace the rechargeable battery in your phone, follow these steps:

1. Remove the Handset battery cover.

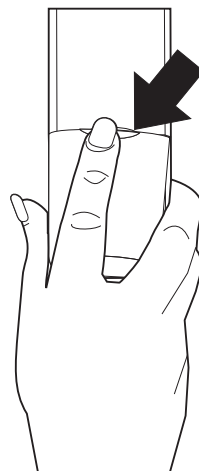

2. Plug the battery's cable into the Handset.

Note: *The plastic connectors will fit together only one way. If you have difficulty, make sure the battery's connector is properly aligned.*

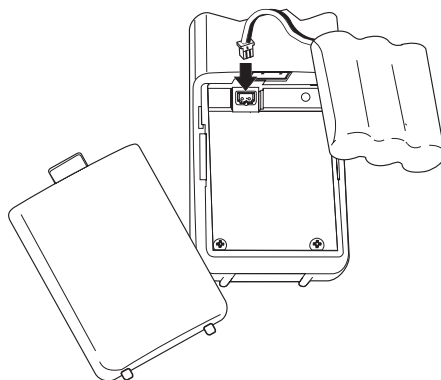

3. Replace the battery cover.

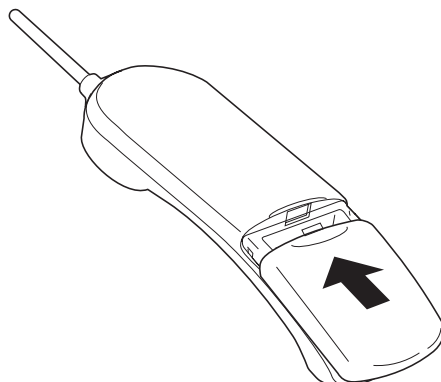

For optimum battery performance:

- Charge the new battery overnight before using your phone.
- Do not let the battery become fully discharged.
- Be sure to return the Handset to the base at night.

Charging the Handset

Place the Handset on the base to charge.

Low Battery Indicator

When the Battery Pack in the Handset is low and needs to be charged, the batt low led flashes every 3 seconds.

If this occurs while you are on the phone, you hear an alert tone. Complete your call as quickly as possible, and return the Handset to the Base Unit for charging.

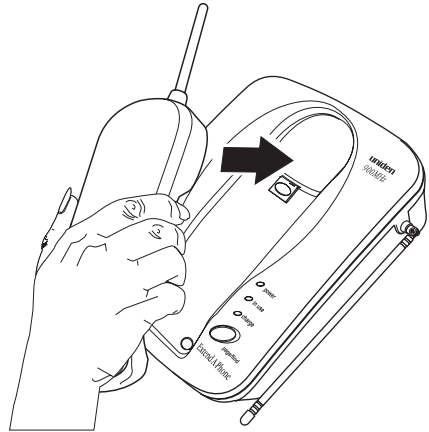

Allow 12 to 16 hours without any interruption for the Handset to fully recharge.

Cleaning the Battery Contacts

To maintain a good charge, it is important to clean all battery contacts on the Handset and Base Unit about once a month. Use a pencil eraser or other contact cleaner. Do not use any liquids or solvents.

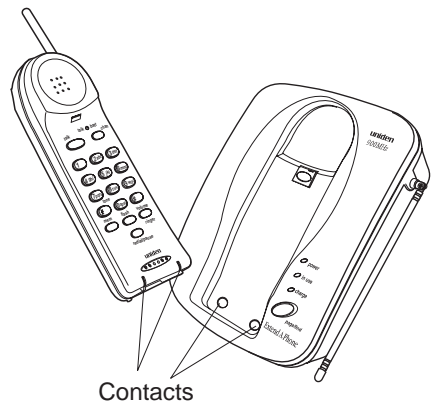



Operating Instructions

Placing a Call

When the Handset Is on the Base

1. Remove the Handset from the Base Unit and press .
2. The talk LED will light.
3. Dial the number you are calling.
4. When you have finished the call, return the Handset to the Base Unit to hang up.

When the Handset Is off the Base

1. Pick up the Handset and press .
2. The talk LED will light up.
3. Dial the number you are calling.
4. When you have finished the call, press the  to hang up.

Answering a Call

When the Handset Is on the Base

1. When the EXP91 rings, remove the Handset from the Base.
2. The talk LED will light, indicating a connection has been made.
3. After you have finished your conversation, return the Handset to the base to hang up.

When the Handset Is off the Base

1. When the EXP91 rings, pick up the Handset and press any key.
2. The talk LED will light, indicating a connection has been made.
3. After you are finished with your conversation, press the  button to hang up.

Selecting a Different Channel

 *If you have more than one cordless phone in your house, they must be set to different channels. This function works only when the phone is in use.*

The  button on the Handset allows you to choose between 40 factory set channels. During the course of a conversation if you hear static or noise which makes it difficult to hear the caller:

1. Press .
2. The talk LED flashes, indicating the EXP91 is changing to another channel.

Using the Flash Button

Use **flash** to send a timed hook-flash for accessing services such as call waiting, etc.

Press the **flash** button on the Handset during your conversation.

Using the Redial Button

The **redial** button dials the last number that you called.

Press **redial**. The last number called is dialed again.

Note: *If any other key is pressed before **redial**, the phone will not redial the last number.*

Storing a Number in Memory

To store a number in memory:

1. Remove the Handset from the Base Unit and press **mem**.
2. The talk LED flashes and you hear a beep.
3. Enter the number you want to store (up to 16 digits).

Note: *You have 20 seconds after pressing **mem** to enter the number you wish to store. Otherwise, an error tone will sound.*

4. Press **mem**.
5. Enter a number (0-9) for the memory location you wish to use.

Note: *If you select any key other than 0-9, the Handset will beep rapidly and no number is stored.*

6. You hear a long beep and the talk LED goes out indicating the number has been stored successfully.
7. Write the stored number and its memory location number on one of the enclosed stickers.

Storing a Mixed Tone/Pulse Numbers

If your phone is set up for Pulse Dialing, you can store a mixed mode number (up to 16 digits) to easily access long distance services.

1. Remove the Handset from the Base Unit and press **mem**.
2. The talk LED flashes and you will hear a beep.
3. Enter the number to be dialed in pulse mode.

Note: *You have 20 seconds after pressing **mem** to enter the number you wish to store. Otherwise, an error tone will sound.*

4. Press the **tone** button on the Handset. The **tone** button counts as one digit.
5. Enter the number to be dialed in tone mode.
6. Press **mem** and a number (0-9) for the memory location you wish to use.

Note: *If you select any key other than 0-9, the Handset will beep rapidly and no number will be stored.*

7. You hear a long beep and the talk LED goes out.
8. Write the stored number and its memory location number on one of the enclosed stickers.

Dialing a Stored Number

To dial a number stored in memory, press **talk**, then press **mem** and the memory location (0-9). Your EXP91 will dial the stored number.

Note: *If you select a memory location that does not have a stored number, the Handset will beep rapidly and will not dial.*

Chain Dialing

On certain occasions, after dialing a number, you may be requested to enter a special access code, such as when performing a banking transaction.

1. Store the access code into one of the memory locations (0-9).
2. Dial the main number.
3. Press **mem** and the memory location of the access code at the appropriate time.

Erasing a Stored Number

1. Remove the Handset from the Base Unit.
2. Press **mem** twice.
3. Press the memory location number (0-9) you want to clear. You will hear a long beep confirming that you have erased the number.

Using the Page Feature

The Page feature sends a signal from the Base Unit to the Handset causing it to beep. This is useful for locating the Handset when it is away from the Base Unit.

1. Press **page/find** on the Base Unit.
2. The Handset beeps several times.

Note: *The paging feature does not work when the phone is in use.*

Adjusting Ringer/Volume Controls

Ringer Tone and Volume

1. While the phone is not in use, press **ringer**.
2. The phone has two ringer tones, each with two volume levels. Press **ringer** again until you select the ringer tone and volume you want.

Setting the Receiver Volume

1. While you are on a call, press **volume**.
2. The phone has two receiver volume levels, one soft and one loud. Press **volume** again until you select the receiver volume you want.

Troubleshooting

If your EXP91 Cordless Telephone is not performing to your expectations, please try these simple steps. If you are still unable to resolve the problems, contact your place of purchase.

Note: *Do not attempt to service this unit yourself. All service must be done by qualified service personnel.*

Problem	Suggestion
Base Unit Power light does not come on.	Make sure the AC Adapter is plugged into the Base Unit and wall outlet.
Charge light won't come on when Handset is placed in Base Unit.	Make sure the AC Adapter is plugged into the Base Unit and wall outlet. Make sure the Handset is properly seated in the Base Unit. Make sure the Rechargeable Battery Pack is properly placed in the Handset. Make sure that the charging contacts on the Handset and on the Base Unit are clean.
Conversation interrupted frequently.	Make sure that the Base Unit antenna is fully vertical. Move closer to the Base Unit. Change Channels.
Handset doesn't ring.	Rechargeable Battery may be weak or not charged fully. Charge the Battery Pack for 4-5 hours. Make sure the Base Unit antenna is fully vertical. The Handset may be too far away from the Base Unit. Check the AC supply.

Range

The EXP91 is designed to achieve the maximum possible range by transmitting and receiving according to the highest specifications set forth by the FCC. We have rated this phone to operate at a maximum distance with the qualification that the range depends upon the environment in which the telephone is used. Many factors limit range, and it would be impossible to include all the variables in our rating. The Maximum Range rating of the EXP91 is meant to be used as a means of comparison against other range claims.

Radio Interference

Radio interference may occasionally cause interruptions in your conversations. When this happens, remember that your unit is not defective. If these noises continue and are too distracting, move to a different location while you are talking on the phone or change channels on your cordless handset.

Specifications

General

Frequency Control	Phase Locked Loop
Modulation	FM
Operating Temperature	-10° - 50° C

Base Unit

Transmit Frequency	925.999 ~ 927.952 MHz (40 Channels)
Power Requirements	9V 210mA (from AC Adapter)
Size	5.3 in. W X 2.2 in. D X 7.7 in. H
Weight	Approximately 20 oz.

Handset

Transmit Frequency	902.078 ~ 904.030 MHz (40 Channels)
Size	2.2 in. W X 2 in. D X 9.75 in. H
Weight	Approximately 10 oz.

Battery

Capacity	600 mAH, 3.6V
Talk Mode	7 hours
Standby Mode	14 days

Specifications shown are typical and subject to change without notice.

EXP 91



Operating Guide

900-MHz Cordless Phone with Voice Scramble

PRECAUTIONS

Before you read anything else,
please observe the following:

WARNING!

Uniden America Corporation **DOES NOT** represent this unit to be waterproof. To reduce the risk of fire, electrical shock, or damage to the unit, **DO NOT** expose this unit to rain or moisture.

RECHARGEABLE NICKEL-CADMIUM BATTERY WARNING

- This equipment contains a Rechargeable Nickel-Cadmium Battery.
- Cadmium is a chemical known to the State of California to cause cancer.
- The Rechargeable Nickel-Cadmium Battery contained in this equipment may explode if disposed of in a fire.
- **Do not** short circuit the battery.
- **Do not** charge the Rechargeable Nickel-Cadmium Battery used in this equipment in any charger other than the one designed to charge this battery as specified in this Guide. Using another charger may damage the battery, or cause the battery to explode.

RECHARGEABLE NICKEL-CADMIUM BATTERIES MUST BE RECYCLED OR DISPOSED OF PROPERLY

- Residents Of Minnesota should contact 1-800-225-PRBA for information concerning reclamation and disposal of Rechargeable Nickel-Cadmium batteries.
- Residents outside of Minnesota should contact their local authorities for information concerning reclamation and disposal of Rechargeable Nickel-Cadmium batteries.



The exclamation point within an equilateral triangle is intended to alert the user to the presence of important operating and maintenance (servicing) instructions in the literature accompanying the appliance.

Base Controls and Indicators

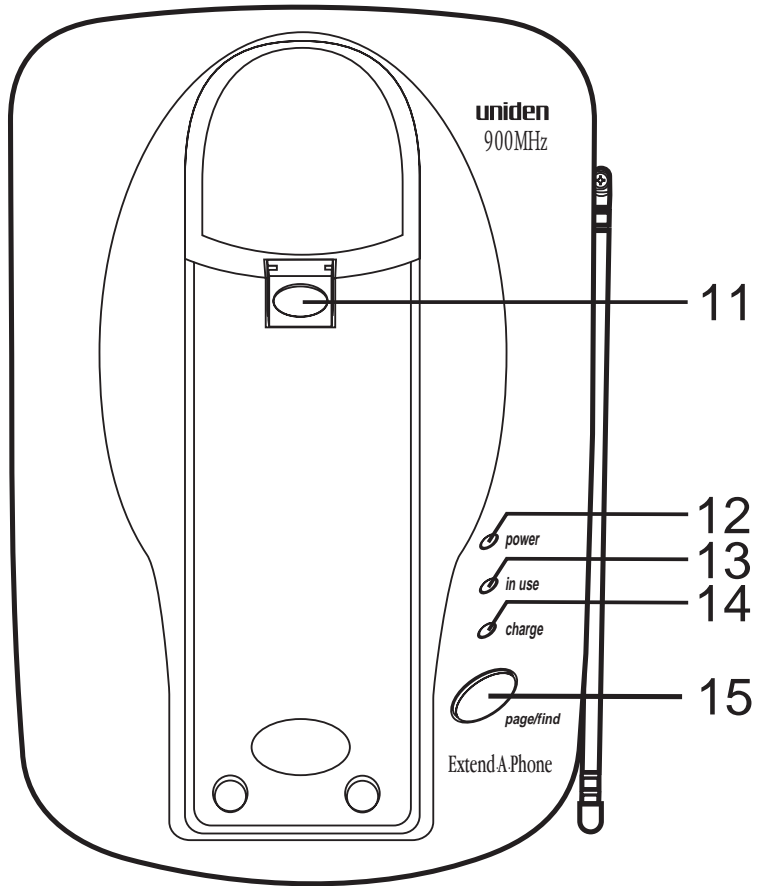

- 11 **handset retainer** - used to hold Handset in Base for wall mounting.
- 12 **power LED** - indicates that AC power is on.
- 13 **in use LED** - indicates the phone is in use.
- 14 **charge LED** - indicates when the handset is charging.
- 15 **page/find** - use to locate the handset.

Handset Controls

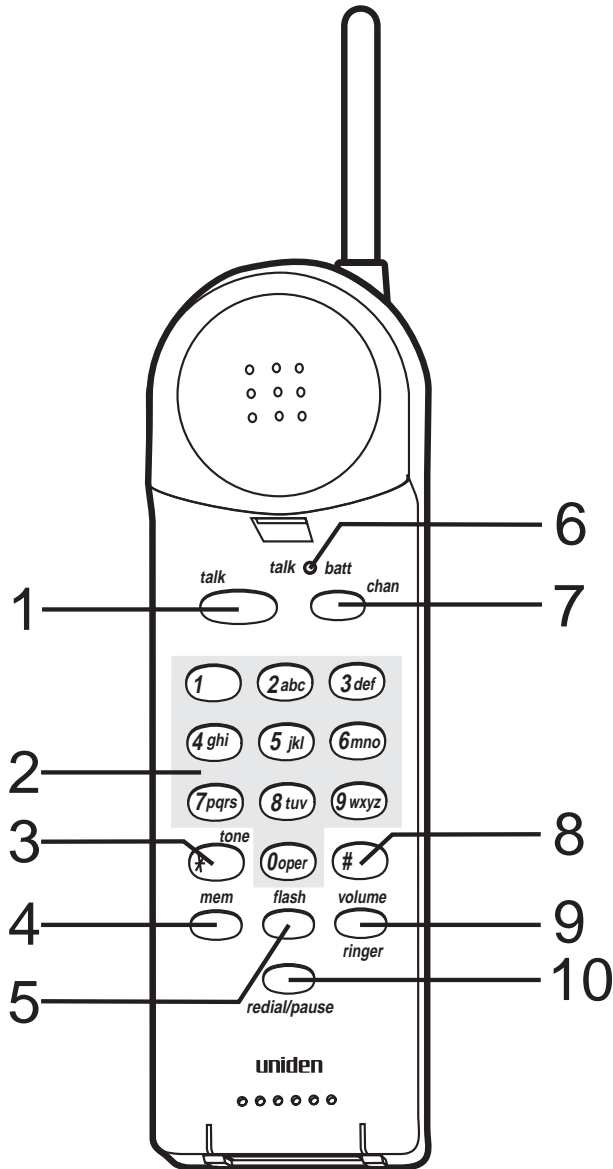

- 1 **talk** - used to answer calls
- 2 **keypad** - touchpad keys
- 3 **(*)/tone** - special access key for some phone systems
- 4 **mem** - used to enter or recall numbers in memory
- 5 **flash** - used to access call waiting (if available)
- 6 **talk/batt low** - indicates when phone is in use or if the battery is low
- 7 **chan** - used to select another channel for clearer reception
- 8 **(#) access key** - special access key for some phone systems
- 9 **volume/ringer volume** - set both the ringer and earphone volumes
- 10 **redial/pause** - redials the last number or adds a memory pause

Contents

Important Safety Instructions	1
Introduction	3
About the EXP91	3
Features	3
What's Included with Your EXP91	4
Installation	5
Installing Your EXP91	5
Selecting the Installation Location	5
Connecting the Telephone Line	5
Setting the Dial Mode Switch	6
Desk or Tabletop Installation	6
Wall Installation	8
Installing the Battery Pack	14
For optimum battery performance:	15
Charging the Handset	15
Low Battery Indicator	15
Cleaning the Battery Contacts	15
Operating Instructions	16
Placing a Call	16
Answering a Call	16
Selecting a Different Channel	16
Using the Flash Button	17
Using the Redial Button	17
Storing a Number in Memory	17
Storing a Mixed Tone/Pulse Numbers	18
Dialing a Stored Number	18
Chain Dialing	18
Erasing a Stored Number	19
Using the Page Feature	19
Adjusting Ringer/Volume Controls	19
Troubleshooting	20
Range	20
Radio Interference	20
Specifications	21
General	21
Base Unit	21
Handset	21
Battery	21

One Year Limited Warranty

Important: Evidence of original purchase is required for warranty service.

WARRANTOR: UNIDEN AMERICA CORPORATION (“Uniden”)

ELEMENTS OF WARRANTY: Uniden warrants, for one year, to the original retail owner, this Uniden Product to be free from defects in materials and craftsmanship with only the limitations or exclusions set out below.

WARRANTY DURATION: This warranty to the original user shall terminate and be of no further effect 12 months after the date of original retail sale. The warranty is invalid if the Product is (A) damaged or not maintained as reasonable or necessary, (B) modified, altered, or used as part of any conversion kits, subassemblies, or any configurations not sold by Uniden, (C) improperly installed, (D) serviced or repaired by someone other than an authorized Uniden service center for a defect or malfunction covered by this warranty, (E) used in any conjunction with equipment or parts or as part of any system not manufactured by Uniden, or (F) installed or programmed by anyone other than as detailed by the Operating Guide for this product.

STATEMENT OF REMEDY: In the event that the product does not conform to this warranty at any time while this warranty is in effect, warrantor will repair the defect and return it to you without charge for parts, service, or any other cost (except shipping and handling) incurred by warrantor or its representatives in connection with the performance of this warranty. THE LIMITED WARRANTY SET FORTH ABOVE IS THE SOLE AND ENTIRE WARRANTY PERTAINING TO THE PRODUCT AND IS IN LIEU OF AND EXCLUDES ALL OTHER WARRANTIES OF ANY NATURE WHATSOEVER, WHETHER EXPRESS, IMPLIED OR ARISING BY OPERATION OF LAW, INCLUDING, BUT NOT LIMITED TO ANY IMPLIED WARRANTIES OF MERCHANTABILITY OR FITNESS FOR A PARTICULAR PURPOSE. THIS WARRANTY DOES NOT COVER OR PROVIDE FOR THE REIMBURSEMENT OR PAYMENT OF INCIDENTAL OR CONSEQUENTIAL DAMAGES. Some states do not allow this exclusion or limitation of incidental or consequential damages so the above limitation or exclusion may not apply to you.

LEGAL REMEDIES: This warranty gives you specific legal rights, and you may also have other rights which vary from state to state. This warranty is void outside the United States of America.

PROCEDURE FOR OBTAINING PERFORMANCE OF WARRANTY:

If, after following the instructions in this Operating Guide you are certain that the Product is defective, pack the Product carefully (preferably in its original packaging). Include evidence of original purchase and a note describing the defect that has caused you to return it. The Product should be shipped freight prepaid, by traceable means, or delivered, to warrantor at:

**Uniden America Corporation
Parts and Service Division
4700 Amon Carter Boulevard
Fort Worth, TX 76155**

(800) 297-1023, 8 AM to 5 PM Central, Monday through Friday

Covered under one or more of the following U.S. patents:
4,511,761 4,523,058 4,797,916 5,426,690

uniden[®]

©1997 Uniden America Corporation
All Rights Reserved
Printed in China